

## 10G BASE-T DUAL PORT LAN FILTER

### Description

- Design for 10G ethernet application. Complying with IEEE 802.3at standard.
- Suitable for End-span POE applications with 720mA current capability.
- Comply with RoHS & Halogen Free requirements.
- Operating temperature range from: -40°C to +85°C.
- Storage temperature range from: -40°C to +85°C.



### Electrical Specifications @ 25°C

Hi-pot:1500 Vrms , Turns Ratio TX/RX(±5%):1CT:1CT , <b>OCL:100(uH Min) @100KHz/0.1V</b>							
Part No	Insertion Loss (dB Max)			Return Loss (dB Min) Load 100Ω			
	1-300MHz	400MHz	500MHz	1-100MHz	200-300MHz	400MHz	500MHz
TL2100	- 1.0	-1.5	-2.0	-18	-12	-11	-10

Part No	Cross talk (dB Min)		DCMR (dB Min)	
	1-100MHz	100-500MHz	1-250MHz	250-500MHz
TL2100	-40	-30	-30	-22

### Mechanical

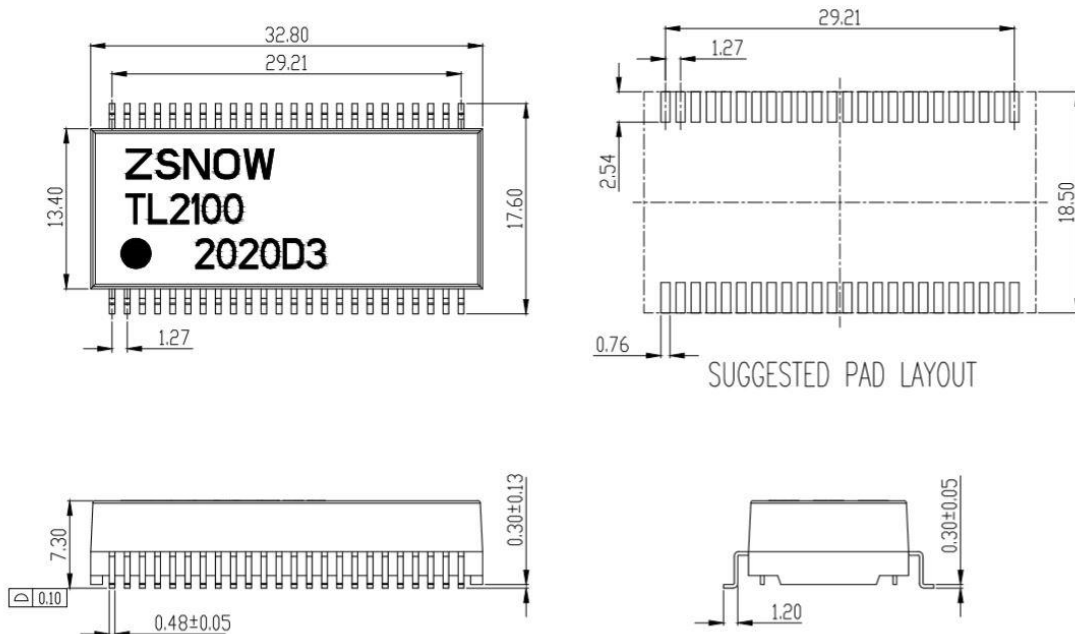

Dimension: mm / Unless otherwise specified, tolerances: ±0.25(mm)

### 10G BASE-T DUAL PORT LAN FILTER

### Schematic

